

CAMRECORD

# Runner

## High-Speed Video Systems



- ✓ RESEARCH
- ✓ TROUBLESHOOTING
- ✓ MOTION CAPTURE AND ANALYSIS

- Small camera head with controller
- Flexible system configuration
- Covering 1 - 65 MPixel and up to 3,500 fps @1 MPixel
- Up to 56 GB video memory
- TimeViewer software with object tracking

## DESCRIPTION

Runner systems combine a high-speed video camera with a separate PC based controller. The systems use a high-speed link between camera and controller to transfer video data in real-time into a large video memory. Application requirements of frame rate and resolution define the camera to be used. Controller and accessories remain unchanged. Runner systems can be configured with different cameras and therefore become very flexible.

Various trigger and synchronization features make the system an ideal tool for trouble shooting, research and industrial applications. The integrated tracking feature to extract trajectory data of moving objects can be used for motion capture and analysis applications.

Model	Frame rate (max.)	Pixel size Image diagonal	Exposure time (min.)	Camera
Runner-1HS-3500-M (mono) Runner-1HS-3500-C (color)	3 500 fps @ 1 280 x 860 pixel : 275 000 fps @ 1 280 x 4 pixel	13.7 µm x 13.7 µm 21.12 mm	2 µs	Cyclone-1HS-3500-M Cyclone-1HS-3500-C
Runner-2-2000-M (mono) Runner-2-2000-C (color)	2 100 fps @ 1 920 x 1 080 pixel : 156 000 fps @ 1 920 x 8 pixel	10 µm x 10 µm 22.03 mm	4 µs	Cyclone-2-2000-M Cyclone-2-2000-C
Runner-5-700-M (mono) Runner-5-700-C (color)	693 fps @ 2 560 x 1 916 pixel : 88 700 fps @ 2 560 x 8 pixel	5 µm x 5 µm 16.00 mm	4 µs	Cyclone-5-700-M Cyclone-5-700-C
Runner-25-150-M (mono) Runner-25-150-C (color)	150 fps @ 5 120 x 5 120 pixel : 20 900 fps @ 5 120 x 4 pixel	2.5 µm x 2.5 µm 18.10 mm	12 µs	Cyclone-25-150-M Cyclone-25-150-C
Runner-65-70-M (mono) Runner-65-70-C (color)	71 fps @ 9 344 x 7 000 pixel : 12 190 fps @ 9 280 x 8 pixel	3.2 µm x 3.2 µm 37.36 mm	12 µs	Cyclone-65-70-M Cyclone-65-70-C

Model	Recording time <sup>1)</sup> 24 GB video memory	Recording time <sup>1)</sup> 56 GB video memory
Runner-1HS-3500-M (mono) Runner-1HS-3500-C (color)	6.7 sec.	15.5 sec.
Runner-2-2000-M (mono) Runner-2-2000-C (color)	5.7 sec.	13.4 sec.
Runner-5-700-M (mono) Runner-5-700-C (color)	7.6 sec.	17.7 sec.
Runner-25-150-M (mono) Runner-25-150-C (color)	6.6 sec.	15.3 sec.
Runner-65-70-M (mono) Runner-65-70-C (color)	5.5 sec.	12.9 sec.

<sup>1)</sup> Recording time is given at max. frame rate and full resolution.

## TRIGGERING AND SYNCHRONIZATION

**Triggering:** Initiates the recording of a sequence. It can be done by software, by change of image content (image trigger) or by an external signal applied to the trigger input of the controller. Post-trigger mode is possible due to video ring memory.

**Synchronization:** A signal applied to the camera allows to define the moment when each image is captured. This is an alternative to fixed frame rate and allows synchronization of cameras in multi camera setups.

## CAMERA AND CONTROLLER CONFIGURATION

The camera is provided with F-Mount for Nikon lenses. Additional mounts for C-Mount lenses and Nikon lenses not having an aperture ring (FMG-Mount) are available.

For high ambient temperatures, an active cooling option is offered. The controller can be equipped with up to 56 GB video memory. For applications requiring even larger video memory custom specific controllers can be configured.

## TimeViewer SOFTWARE

Runner systems are controlled by TimeViewer software. It is installed on the controller but also provided separately for installation on a remote PC. The software is used for single and multiple camera setups. It also integrates a tracking feature to extract trajectory data of moving objects. Video memory is configured as a ring memory to allow post-trigger operation.

Key features:

- Automatic recording start by image trigger
- Freely adjustable pre- and post-trigger
- Object tracking
- Preview images for simplified navigation
- Synchronous multi-camera control
- Export of AVI formats
- Capture of trajectories
- Measurement of distance, angle, speed
- Insertion of logo and text into sequences

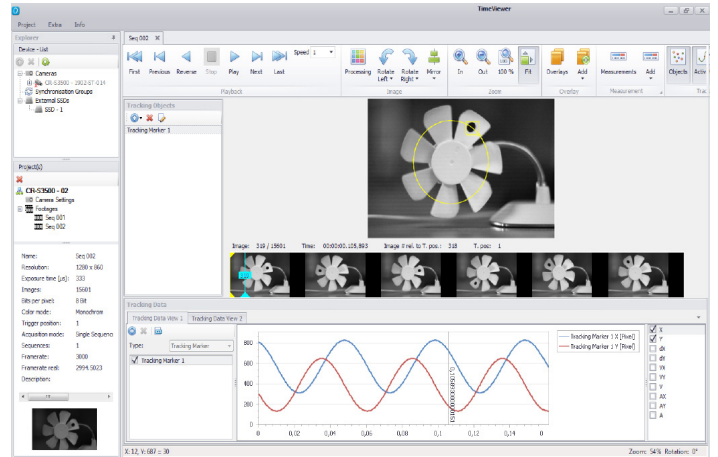

## SETUP

Basically, the camera is connected to the controller for power supply and data transfer. User control in stand-alone configuration is provided via additional keyboard, mous and monitor. For remote operation only Ethernet connection is used. Multi-camera configurations are possible also.

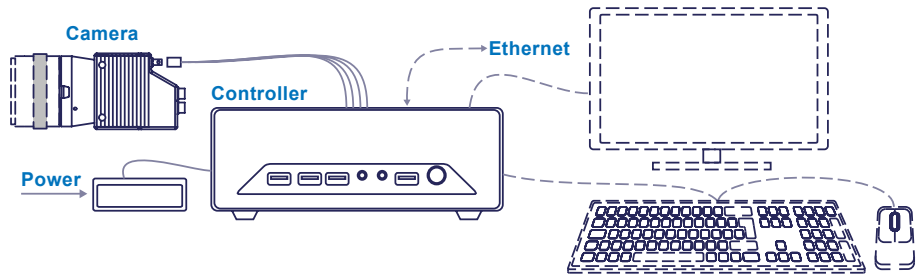

## STAND-ALONE OPERATION

The system can be operated stand-alone by connecting keyboard, mouse and monitor. After capturing a video sequence it can be saved on the hard disk of the controller. Transfer of video data to external devices is done by using Ethernet or USB interface.

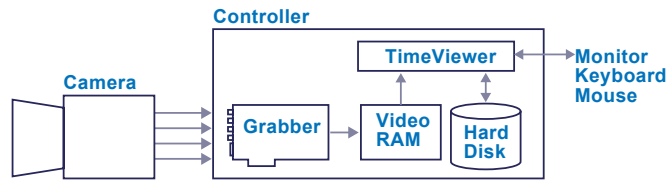

## REMOTE OPERATION

Using a separate PC allows to operate Runner systems in remote mode. In this configuration video sequences are saved on the hard disk of the remote PC.

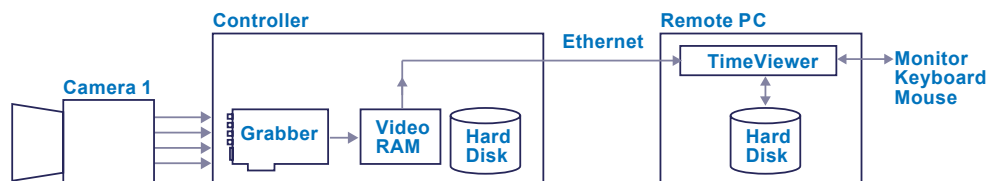

## MULTI-CAMERA OPERATION

Multi-camera systems can be configured by connecting multiple Runner systems via Ethernet to the remote PC. Additionally to Runner systems, CamRecord-Sprinter and CamRecord-CR cameras can be used. Alternative to a remote PC, multi-camera systems might be controlled by one of the controllers.

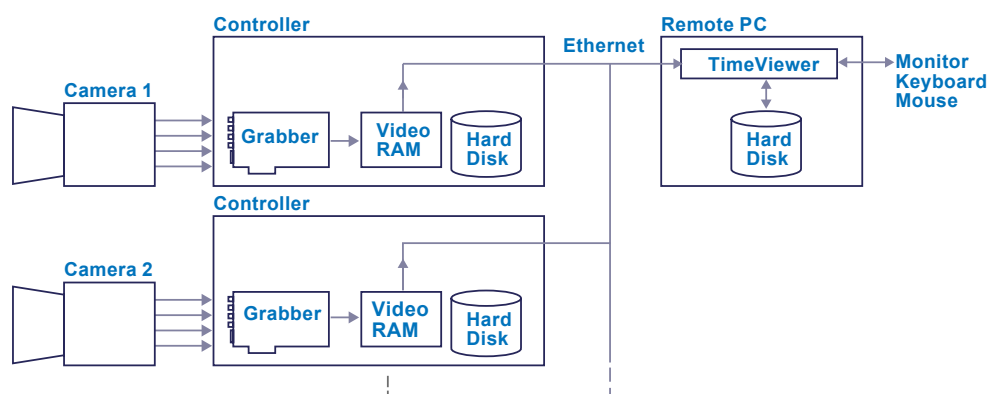

## CAMERA

Lens mount	F-mount (standard)
Synchroization	Internal, External, CXP
Synchroization signal (external)	Synch IN, Synch OUT, TTL level, electrically isolated
Dimensions	98 x 65 x 71 mm <sup>3</sup>
Weight (aprox.)	700 g
Temperature range	0 - 40 °C (32 - 104 °F) 0 - 35 °C (32 - 96 °F) only Runner-65-70 0 - 55 °C (32 - 131 °F) with CY-FAN

## CONTROLLER-RC1

Video memory	24 GB (opt. 56 GB)
Hard disk	1 TB, SSD
Operating system	Win 10 pro, english
Trigger input	D-SUB HD 26p fem., TTL
Dimensions (aprox.)	205 x 270 x 80 mm <sup>3</sup> , 1.8 kg
Supply	100 - 240 V, 50 - 60 Hz
Temperature range	0 - 40 °C (32 - 104 F)
Interfaces	HDMI, 4x USB2, 4x USB3, GigE, D-SUB HD26 for trigger input

## SPECIFICATIONS

A/D conversion	8 Bit
Trigger modes	Rising or falling edge, software, manually by handtrigger, pre- and post-trigger
Memory configuration	Ring Memory
Scope of delivery	Camera, F-mount lens adapter (CY-FM), passive heat sink (CY-HIS), CXP cable (4 x 3 m), controller with 24 GB video memory, TimeViewer software, Manual on USB, transport case

## ACCESSORIES

CP-CM	C-Mount lens adapter
CP-FMG	F-Mount lens adapter with aperture control
CP-FAN	active cooling option
CABLE-HDBNC-5m	CXP Cable 4 x 5 m
CABLE-HDBNC-10m	CXP Cable 4 x 10 m
CABLE-HDBNC-40m	CXP Cable 4 x 40 m
Mem-56GB	Upgrade to 56 GB video memory
CR-TAR	Trigger Adapter HD26 D-SUB to BNC female
CR-HTR	Manual Trigger Device, 1.8 m
CPH6-PTC	Pig tail cable for synch

## TECHNICAL DRAWING

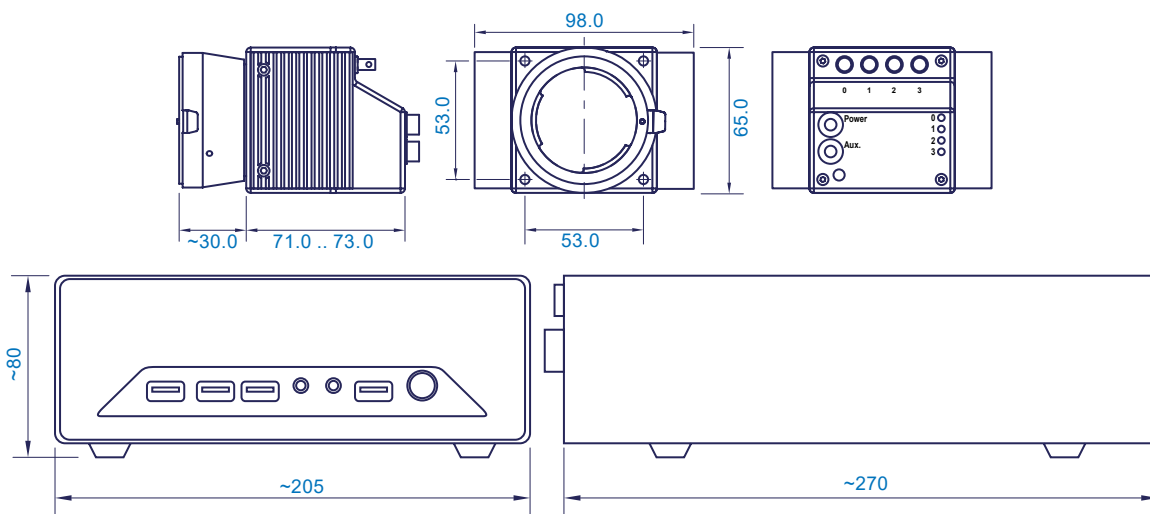

## CONTACT INFORMATION

Optronis GmbH  
Ludwigstraße 2  
77694 Kehl  
Germany

Phone: +49 7851 91 26 - 0  
Fax: +49 7851 91 26 - 10  
info@optronis.com  
www.optronis.com